

ROBA[®]-contitorque

Perfect
torque limitation

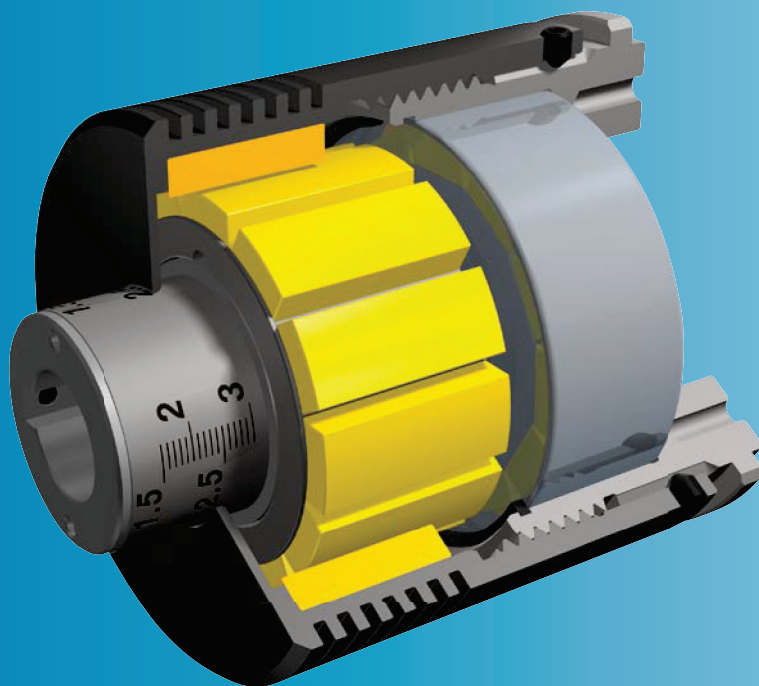

*Continuous slip clutches and brakes
with magnetic hysteresis principle*

- *Precise torque limitation*
- *Contactless torque transmission*
- *Wear-resistant and maintenance-free*
- *Load holding*

www.mayr.com

K.150.V09.GB

mayr[®]
your reliable partner

Construction and Development

Innovations for Your Success

With our innovative and economical solutions, we are able to set new records in the field of power transmission. Our many worldwide patents prove our constant ambition of developing better and technologically superior products.

Highly qualified engineers, high-performance 3D-CAD-systems and the most up-to-date FEM calculation aids used in our Development and Construction departments mean that our business is perfectly equipped to offer our customers effective solutions.

Experts for all Drive-technological Questions

Exploit our know-how, gained by decades of experience in the development, production and application of power transmission products. Our experts in Construction and Development are happy to advise you personally and competently when selecting and dimensioning the drive solution you require.

From Prototype to Finished Product

No mayr® product is released onto the market until it has proved its functional capabilities and reliability in extreme, long-term tests.

The spectrum of testing equipment is as varied as our range of products:

- Friction work test stands
- Wear test stands
- Noise measurement room with highly accurate noise measurement inspection devices
- Torque measurement stands up to 200.000 Nm
- Impact- and continuous-operation alternating load test stands
- Force test stands
- Linear movement test stands
- Continuous performance test stands
- Magnetic flow measurement test stands
- High-speed test stands up to 20.000 rpm
- Misalignment and angular misalignment test stands
- Load and measurement test stands for DC motors

Product Data: Our 24-hour Service

Our website offers you detailed information 24 hours per day, 365 days per year with no delays. Here you can find not only the latest catalogues and technical documentation but also CAD-files for cost-saving construction of our products.

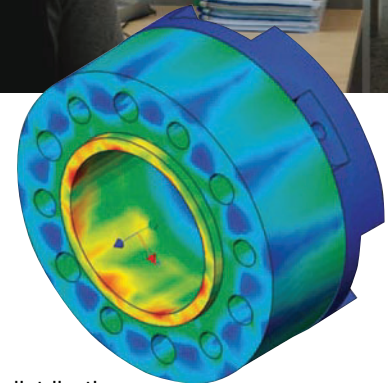
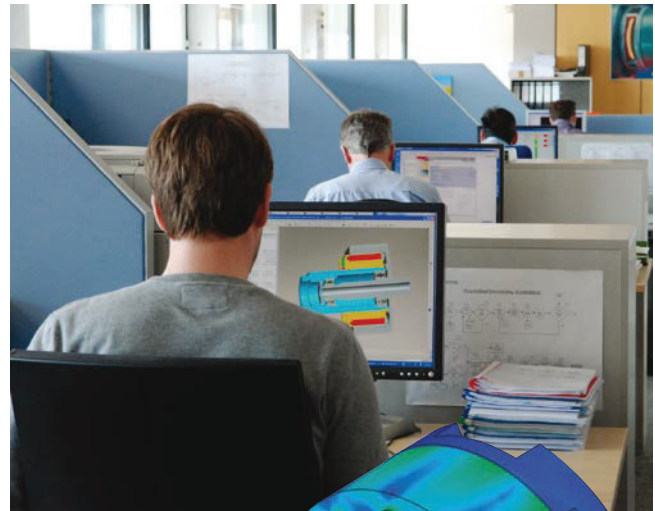
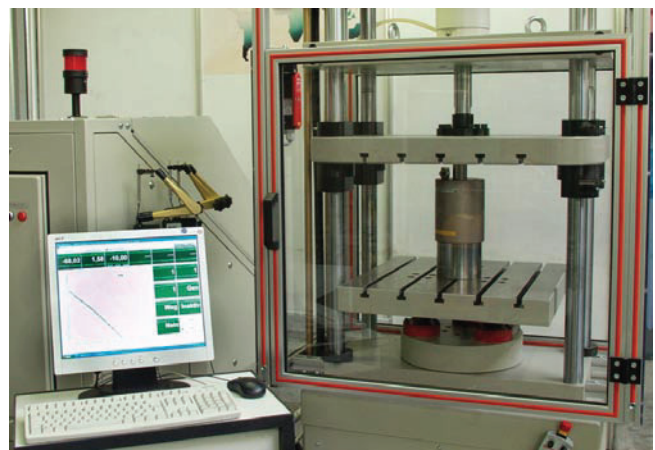

Illustration of the stress distribution in a backlash-free connection

Please Observe:

According to german notation, decimal points in this document are represented with a comma (e.g. 0,5 instead of 0.5).



Unsurpassed - Our Standard Programme

As worldwide market leaders, we are able to offer the largest product range of load holding, load separating, torque and force-limiting, frictionally-locking, magnetic, controllable and switchable safety clutches. We can also provide you with the optimum protection element for your application.

ROBA®-contitorque

If you require wear-free and reliable torque limitation, the ROBA®-contitorque continuous slip clutch and brake is your ideal partner.

Contrary to friction type clutches the torque is transmitted contactlessly via magnetic forces.

Characteristics and advantages of the ROBA®-contitorque:

- contactless torque transmission
- excellent torque repetitive accuracy
- precise torque limitation
- free of wear – no contamination due to abrasion
- maintenance-free
- load holding
- applicable as clutch or brake
- compact design
- robust bearing
- easy graduated torque adjustment with direct torque indication
- low weight and mass moment of inertia

Function in smooth operation

The ROBA®-contitorque synchronously transmits the set torque from an input shaft to an output element, which can be attached to the clutch flange (Fig. 1).

Here, the operational torque T_B is below the limit torque T_g of the clutch (Fig. 2).

The torque is transmitted contactlessly via magnetic forces, which are generated by permanent magnets, and which magnetise hysteresis material.

Function in case of overload

If the operational torque T_B exceeds the set limit torque T_g the clutch slips, i.e. input and output components rotate to each other with a relative speed n_s , the so-called slip speed (Fig. 2). The hysteresis material is constantly magnetised and demagnetised and the clutch becomes warm.

The torque is transmitted asynchronously.

The clutch torque T_k also remains on the level of the set limit torque T_g in case of overload.

The set limit torque T_g also increases with increasing relative speeds due to eddy-current effects (Fig. 3).

Contact the manufacturer as to exact values for T_g and torque characteristic of the clutch.

After removal of the overload, the relative speed n_s returns to zero and the torque is again synchronously transmitted between input and output components.

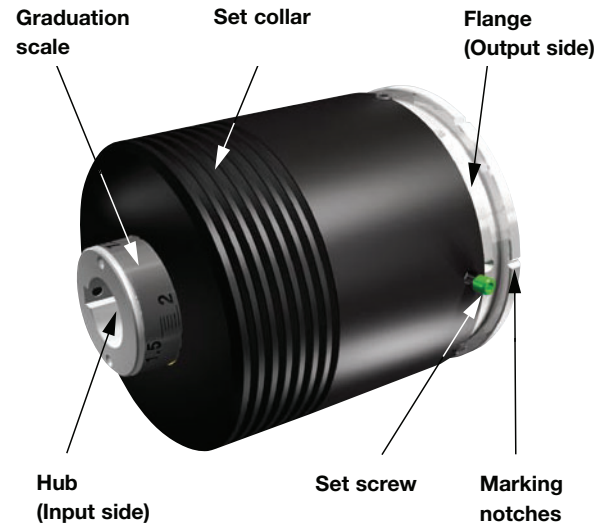

Fig. 1

Torque adjustment

The torque on the ROBA®-contitorque must only be adjusted step-wise. After each step-wise adjustment, the clutch must slip, so that no pulsating torque occurs.

The ROBA®-contitorque is characterised by its quick and easy torque adjustment.

If no special torque is defined with the order, the clutch is set to the maximum torque at the factory. The set torque can be determined by means of a graduation scale, that can be found on the hub (Fig. 1).

If the torque requires setting to another value you have to (Fig. 1)

- loosen the radial set screws,
- hold the knurled flange and manually turn the set collar until the graduation scale indicates the required torque value,
- slightly correct the set collar until the marking notches of the flange and the set screws align axially,
- tighten the set screws again.

Clutch torque T_k in case of overload

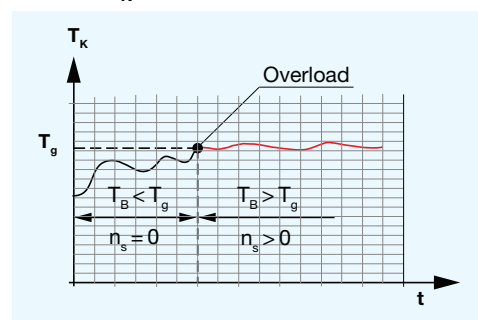

Fig. 2

Torque characteristic

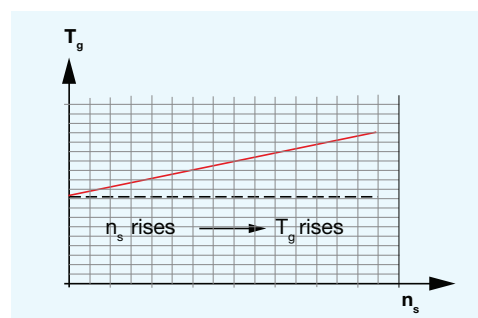
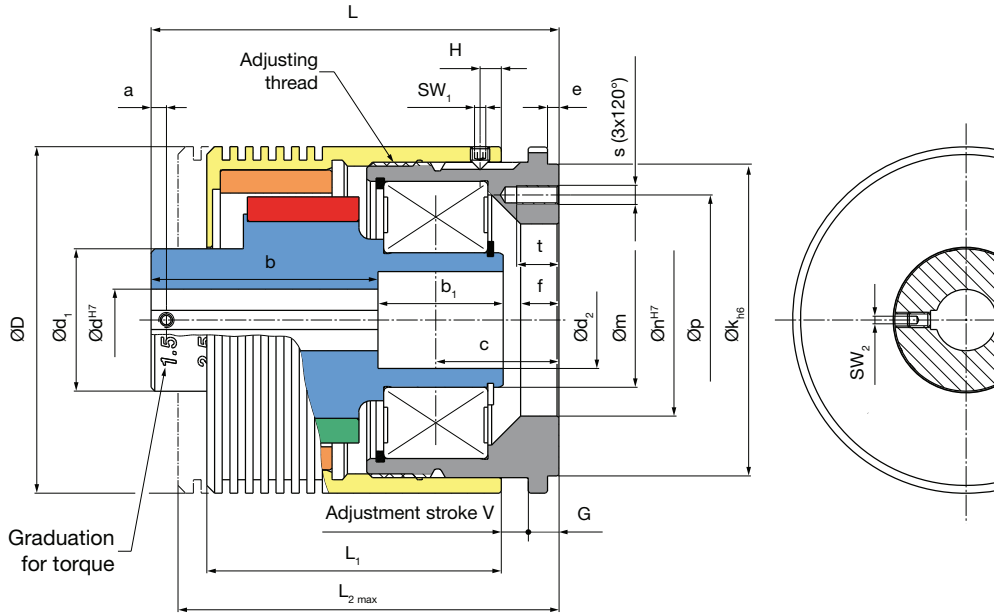

Fig. 3



Order Number

_ / 1 5 0 . _ 0 0 / _ / _			
▲		▲	▲
Size 1 to 5	low torque range ⁷⁾ high torque range ⁷⁾	1 2	Hub Bore Ø d (depending on size)
			Keyway acc. DIN 6885-1 or DIN 6885-3

Example: 1 / 150.100 / 12 / 6885-1; 4 / 150.200 / 38 / 6885-3

- 1) Request the tolerance values for the maximum deviation of the set limit torque T_g from the scale value at the manufacturer's. Torque repetitive accuracy $\pm 2\%$. At high relative speeds, the limit torque T_g increases due to eddy current effects. Please contact the manufacturer for exact T_g values.
- 2) Refers to the maximum surface temperature of c. 90 °C for non-rotating set collar.
- 3) Application temperature in the range 0 – 45 °C.
- 4) The maximum permitted speed in slipping operation must be calculated via thermal design (see page 8).
- 5) Referring to a nominal bearing service lifetime $L_{10h} = 30000$ h, a radial force F_{rad} lever arm at a maximum distance of 100 mm from the bearing centre and a bearing speed n_{max} .
- 6) Other mounting dimensions or bores on request.
- 7) See Table "Technical Data", limit torque on overload

Other sizes for lower and higher torques on request.

We reserve the right to make dimensional and constructional alterations.

Technical Data				Size						
				1	2	3	4	5		
Limit torque ¹⁾ on overload	Type 150.100 (low torque range)	$T_{g\ min}$	[Nm]	0,1	0,1	0,1	0,2	0,5		
		$T_{g\ max}$	[Nm]	0,4	0,8	1,5	3	6		
	Type 150.200 (high torque range)	$T_{g\ min}$	[Nm]	0,4	0,8	1,5	3	6		
		$T_{g\ max}$	[Nm]	0,8	1,6	3	6	12		
Permitted power loss ²⁾	at application temperature ³⁾	0 - 25 °C	$P_{V, perm.}$	[W]	70	79	90	122	152	
		26 - 35 °C			59	67	76	103	129	
		36 - 45 °C			48	55	62	84	106	
Maximum permitted mechanical speed ⁴⁾				η_{max}	[rpm]	4000	3500	3000	3000	3000
Permitted bearing load ⁵⁾	radial	F_{rad}	[N]	105	220	340	560	1115		
	axial	F_{ax}	[N]	70	145	230	375	744		

Mass moments of inertia and weight für $\varnothing d_{middle}$ and keyway DIN 6885-1				Size				
				1	2	3	4	5
Inner part (hub)	Type 150.100	J_i	[10 ⁻³ kgm ²]	0,034	0,165	0,384	1,181	4,329
	Type 150.200			0,043	0,193	0,474	1,448	5,166
Outer part (flange + set collar)	Type 150.100	J_a	[10 ⁻³ kgm ²]	0,237	0,644	1,31	3,725	11,944
	Type 150.200			0,27	0,735	1,5	4,361	13,706
Weight	Type 150.100		[kg]	0,59	1,28	1,72	3,04	6,06
	Type 150.200		[kg]	0,69	1,44	1,97	3,53	6,88

Bores				Size						
				1	2	3	4	5		
Hub bore $\varnothing d^{H7}$ with keyway according to DIN ⁶⁾	6885-1	of	$\varnothing d_{min}$	[mm]	10	12	15	18	20	
		to		[mm]	12	17	22	35	45	
	6885-3	over		[mm]	12	17	22	35	45	
		to	$\varnothing d_{max}$	[mm]	14	20	25	38	50	
Middle hub bore				$\varnothing d_{middle}$	[mm]	12	16	20	28	35

Dimensions [mm]	Size				
	1	2	3	4	5
a	3,5	3,5	4	4,5	5,5
b	45	53	61	73	86
b ₁	26	30,5	33	37,5	49
c	26	30,4	33,5	38,9	51,15
d ₁	26	31	37	52	75
d ₂	14,2	20,2	25,2	38,2	50,2
D	62	77	90	113	145
e	3	3	3	3	5
f	8	8	10	10	12
G	7,7	7,7	7,7	8,7	15,7
H	5	5	5,5	6	6
k _{h6}	54	69	81	103	133

Dimensions [mm]	Size				
	1	2	3	4	5
L	83	98	110	129	160
L ₁	58,5	70,5	80	93,5	111
L _{2max}	76,5	91,5	103	120,5	149,5
m	20	30	35	50	65
n ^{H7}	32	42	50	70	90
p	43	55	65	86	111
s ⁶⁾	M4	M4	M5	M6	M8
SW ₁	2	2	2,5	2,5	2,5
SW ₂	2	2	2	2,5	3
t	8	8	11	13	18
v	0,3 - 10,3	0,3 - 13,3	0,3 - 15,3	0,3 - 18,3	0,3 - 22,8

Rustproof

Type 151.300
 Sizes 3 - 4

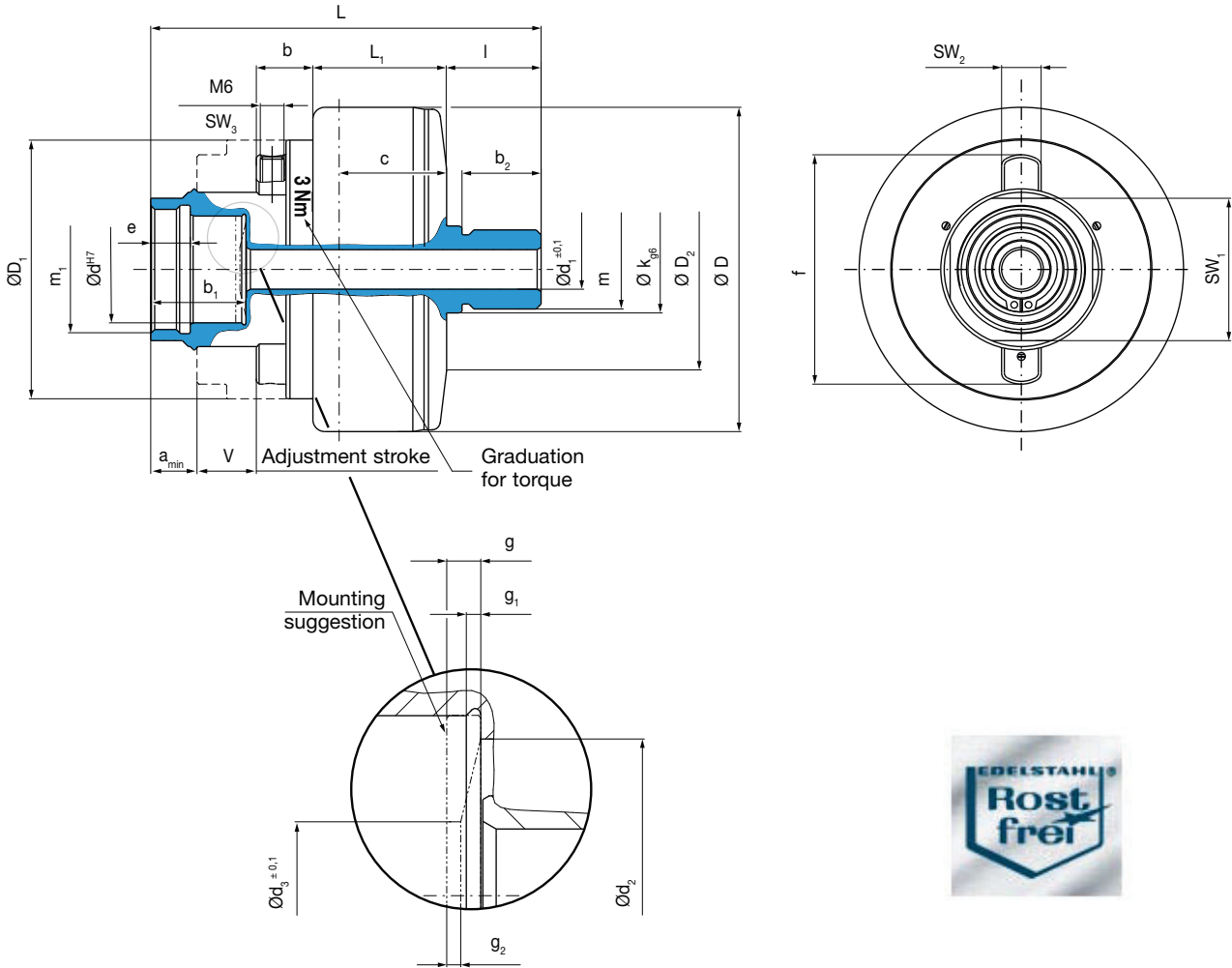

Order Number

— / 1 5 1 . 3 0 0



Size
 3
 to
 4

Example: 3 / 151.300

- 1) Request the tolerance values for the maximum deviation of the set limit torque T_g from the scale value at the manufacturer's. Torque repetitive accuracy $\pm 2\%$. At high relative speeds, the limit torque T_g increases due to eddy current effects. Please contact the manufacturer for exact T_g values.
- 2) Refers to the maximum surface temperature of c. 100 °C for rotating housings ($n = 200$ rpm).
- 3) Application temperature in the range 0 - 45 °C.
- 4) Referring to a nominal bearing service lifetime $L_{10h} = 20000$ h, a radial force F_{rad} lever arm at a maximum distance of 70 mm from the bearing centre and a bearing speed $n = 350$ rpm.

Further sizes for smaller and larger torques on request.

Technical Data				Size	
				3	4
Limit torque on overload ¹⁾		T_g	[Nm]	0,5 – 3	0,5 – 6
			[in-lbs]	5 – 27	5 – 53
Permitted power loss ²⁾ at application temperature ³⁾ [°C]	0 - 25 °C	$P_{V,perm.}$	[W]	26	34
	26 - 35 °C			22	29
	36 - 45 °C			18	23,5
Permitted speed		n_{max}	[rpm]	The maximum permitted speed in slipping operation must be calculated via the thermic dimensioning (see page 8)	
Permitted bearing load ⁴⁾	radial	F_{rad}	[N]	325	390
	axial	F_{ax}	[N]	217	260

Mass moments of inertia and weight				Size	
				3	4
Input side (hub)		J_i	[10 ⁻³ kgm ²]	0,541	1,724
Output side (housing)		J_a	[10 ⁻³ kgm ²]	0,779	2,375
Weight			[kg]	1,70	3,34

Dimensions [mm]	Size	
	3	4
a_{min}	13	11,7
b	14,6	12,8
b_1	24	24
b_2	20	20
c	35,65	43
d^{H7}	27	27
$d_1^{\pm 0,1}$	9	9
$d_2^{\pm 0,1}$	23,5	23,5
$d_3^{\pm 0,1}$	11	11
e	10	10
f	64	76
g	2,5	2,5
g_1	1,07	1,07
g_2	1	1
D	82	104
D_1	65,4	83,4
k_{g6}	22	22
l	24	24
L	117,5	131,7
L_1	40,4	48,2
m	M20 x 1,5	M20 x 1,5
m_1	M32 x 1,5	M32 x 1,5
SW_1	36	41
SW_2	10	10
SW_3	3	3
V	0 – 25,5	0 – 35



Thermal design of the clutch

The ROBA®-contitorque slips in case of overload, i.e. input and output components rotate to each other with a relative speed, the so-called slip speed.

The hysteresis material is constantly magnetised and demagnetised by the magnetic field of the permanent magnets. On that occasion a power loss occurs, which must be dissipated to the environment in form of heat.

Otherwise the clutch would overheat unpermittedly and the magnetic material would get damaged.

The power loss in a continuous slip operation depends on the set clutch torque and the slip speed.

If the clutch is used e.g. with an assembly cycle and only slips a certain part of the complete cycle duration, then the calculated heat loss can be reduced in contrast to the continuous slip operation by means of the reduction factor V.

$$P_v = \frac{T \times n_s}{9,55} \times V \leq P_{v,perm.}$$

$$V = \frac{t_s}{t_{cycle}} \text{ und } t_s^{1)}$$

t_s	≤ 30 s for Size 1
	≤ 25 s for Size 2
	≤ 20 s for Size 3
	≤ 15 s for Size 4
	≤ 10 s for Size 5

The following applies to continuous slip operation: **V = 1**

- P_v = power loss of the clutch/brake [W]
- $P_{v,perm.}$ = permitted power loss of the clutch/brake [Nm]
- T = torque of the clutch/brake [Nm]
- n_s = slip speed [rpm]
- V = reduction factor [-]
- t_s = slipping period [s]
- t_{cycle} = cycle period [s]

¹⁾ Valid for maximum torque adjustment with Type 150.200 and slip speed $n_s = 3\,000$ rpm.
For other torques and slip speed values for t_s , please contact the manufacturer.

The following diagram shows the operating characteristic curve of the continuous slip clutch and brake ROBA®-contitorque.

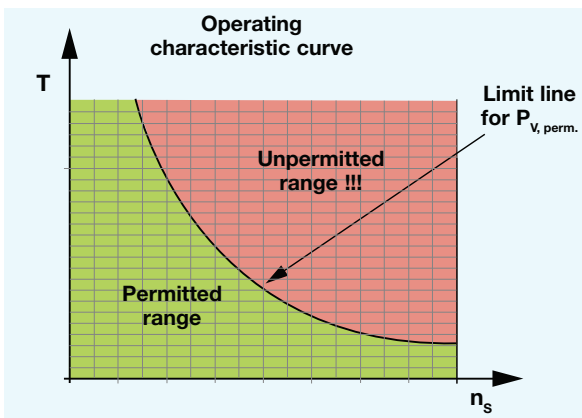

The green range below the limit line of $P_{v,perm.}$ shows the permitted range, in which the continuous slip clutch and brake does not overheat.

If the operating point lies in the red range, above the limit line, the clutch overheats unpermittedly and could be destroyed.

Design examples

Winding on and off of foil, yarn, wire etc.
(Application as brake in a continuous slip operation)

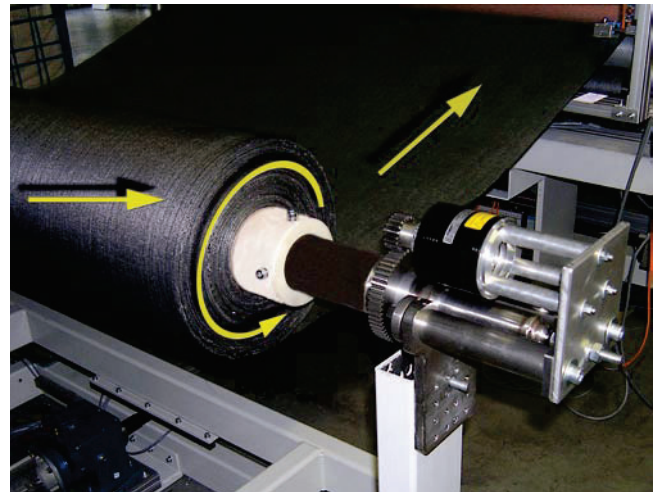

Given:

- F = 20 N Winding tension
- v = 2 m/s Winding speed
- d = 0,2 m Winding diameter roll
- V = 1 [-] Continuous slip operation
- 30 °C Operation temperature

Required:

- T = ??? Brake torque
- n_s = ??? Brake slip speed
- P_v = ??? Brake power loss

$$T = F \times d/2 \Rightarrow T = 20 \text{ N} \times 0,2\text{m}/2 = 2 \text{ Nm}$$

$$v = r \times \omega = d/2 \times 2 \pi \times n_s \Rightarrow n_s = \frac{v}{d \times \pi}$$

$$n_s = \frac{2 \text{ m/s}}{0,2 \text{ m} \times \pi} = 191 \text{ rpm}$$

$$P_v = \frac{T \times n_s}{9,55} \times V = \frac{2 \text{ Nm} \times 191 \text{ rpm} \times 1}{9,55} = 40 \text{ W}$$

Selected:

=> ROBA®-contitorque, Size 3, Type 150.200 with $T_g = 1,5 - 3$ Nm and $P_{v,perm.} = 76 \text{ W} > P_v = 40 \text{ W}$

Screwing on sealing caps

(Application as clutch in an assembly cycle)

Given:

- T = 2,5 Nm Sealing cap screw-on torque
- n_s = 300 rpm Screwing speed
- t_s = 2 s Slipping period
- t_{cycle} = 10 s Cycle period

40 °C Operation temperature

Required:

- P_v = ??? Clutch power loss

$$V = \frac{t_s}{t_{cycle}} = \frac{2 \text{ s}}{10 \text{ s}} = 0,2$$

$$P_v = \frac{T \times n_s}{9,55} \times V = \frac{2,5 \text{ Nm} \times 300 \text{ rpm} \times 0,2}{9,55} = 15,7 \text{ W}$$

Selected:

=> ROBA®-contitorque, Size 3, Type 151.300 with $T_g = 0,5 - 3$ Nm and $P_{v,perm.} = 18 \text{ W} > P_v = 15,7 \text{ W}$

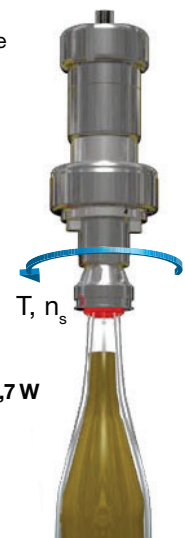

Safety Regulations

During operation of the clutch, its surface may become very hot. In this case, the user must avoid direct contact with the clutch, otherwise they may suffer injury.

The clutch housings have a safety label applied to them as a standard measure (Caution: hot surface) with the exception of the Types 151._00.

The user can be protected from injuries by taking further safety measures:

- a) Mount guideline signs (Caution: hot surface) near to the clutch (responsibility of the customer)
- b) Enclose the clutch assembly (responsibility of the customer)

The clutch must always be installed so that direct heat exchange with the surroundings can take place unimpeded (do not cause heat accumulation when adding mounted parts). Encapsulation must not hinder the heat exchange.

Installation and effect must be carried out by appropriately trained personnel.

There is a risk of injury to personnel caused by the rotating clutch or rotating clutch parts.

The clutch works using strong magnetic fields. Strong magnetic fields could disrupt or destroy electronic or mechanical devices.

This is particularly the case for pacemakers.

Any data stores on credit cards, hard drives or disks could be deleted.

In order to avoid this, please maintain a sufficient distance (larger than 0,2 m).

The clutch must not be subjected to impact loads, as the magnets are extremely hard and brittle and can splinter on impact. Another risk is that mechanically-generated sparks can be caused by impact loads. For this reason, the clutch must not be operated in explosive atmospheres.

The clutch must not come into direct contact with metal chips, as these will be attracted by the magnetic fields, will contaminate the clutch and may disrupt its function.

The clutch housing must not under any circumstances be removed completely. Clutch parts will move due to the strong magnetic fields. This could result in seizure injuries.



- **Danger of injury due to hot surfaces**



- **Danger of injury due to seizure during clutch installation and deinstallation**



- **Danger for people with pacemakers**

Installation

Shaft fixing

The radial securement of the clutch onto the shaft takes place using a key connection.

The clutch can either be fixed onto the shaft using a screw and press cover (Fig. 4) or using a set screw (Fig. 5).

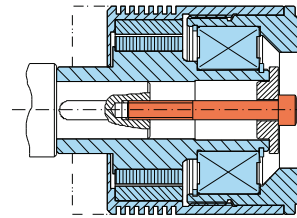

Fig. 4

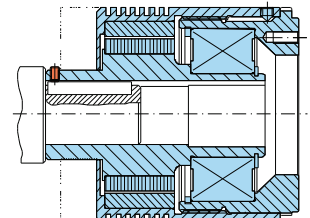

Fig. 5

Output elements (see also Installations Examples page 11)

Output elements can be centred onto the two flange key diameters and than screwed to the flange.

Dimensions Tables for Key Connections

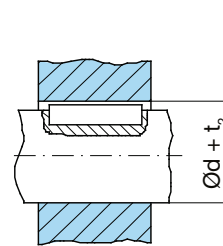

Fig. 6

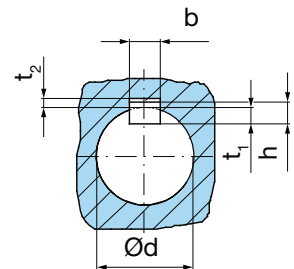

Fig. 7

Diameter d [mm]		According to DIN 6885-1			
		Width b ¹⁾ [mm]	Height h [mm]	Shaft keyway depth t ₁ [mm]	Hub keyway depth d + t ₂ [mm]
above	up to				
8	10	3	3	1,8	d + 1,4
10	12	4	4	2,5	d + 1,8
12	17	5	5	3	d + 2,3
17	22	6	6	3,5	d + 2,8
22	30	8	7	4	d + 3,3
30	38	10	8	5	d + 3,3
38	44	12	8	5	d + 3,3
44	50	14	9	5,5	d + 3,8

Diameter d [mm]		According to DIN 6885-3			
		Width b ²⁾ [mm]	Height h [mm]	Shaft keyway depth t ₁ [mm]	Hub keyway depth d + t ₂ [mm]
above	up to				
12	17	5	3	1,9	d + 1,2
17	22	6	4	2,5	d + 1,6
22	30	8	5	3,1	d + 2,0
30	38	10	6	3,7	d + 2,4
38	44	12	6	3,9	d + 2,2
44	50	14	6	4,0	d + 2,1

¹⁾ The tolerance field of the hub keyway width b is JS 9

²⁾ The tolerance field of the hub keyway width b is J 9

Application Examples

Screwdriving Technology

- Screwing on of various sealing caps with a defined torque



Test Stand Technology

- Simulation of defined loads

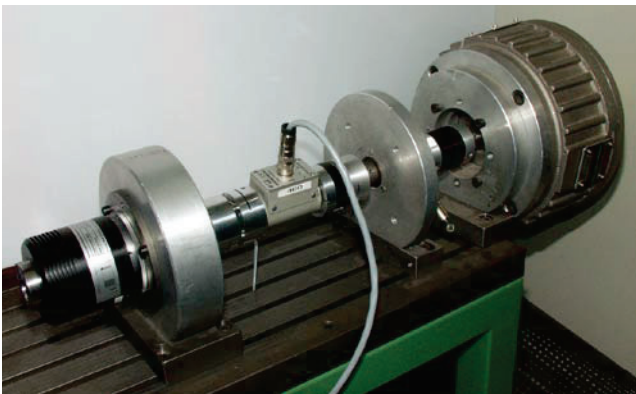

General Power Transmission

- Torque limitation with polishing machines



Winding on and off Technology

- Tensile force limitation when winding on and off yarns, wires, foils etc.



General Power Transmission

- Torque limitation in railway switch point drives

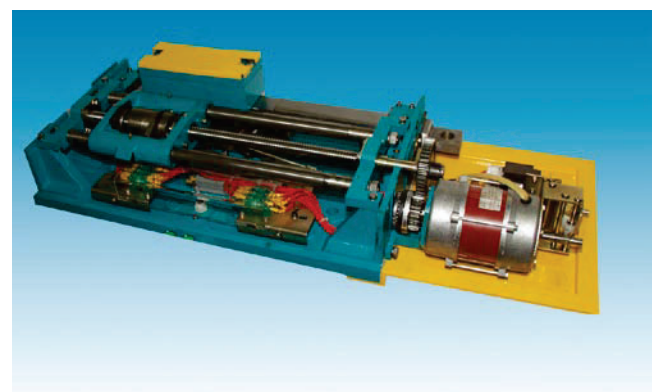

Installation Examples

ROBA®-contitorque with installed pulley (used as a clutch or as a brake)

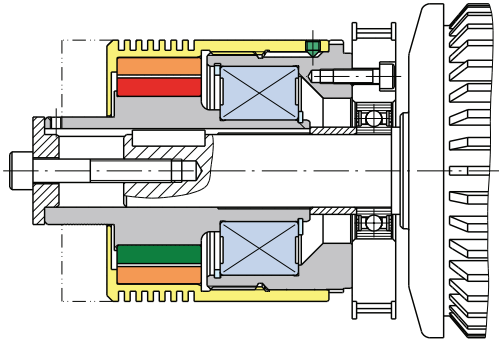

The clutch is secured directly onto the motor shaft and the pulley is bearing-mounted separately using the deep groove ball bearing (used as a clutch for torque limitation).

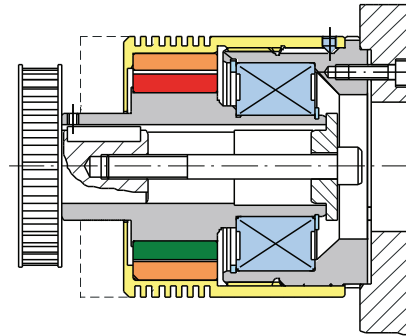

The pulley is installed directly onto the clutch. The clutch functions as a bearing for the pulley and is rigidly connected to a machine wall (used as a brake for tensile force limitation of a belt).

ROBA®-contitorque with winding drum (used as a brake)

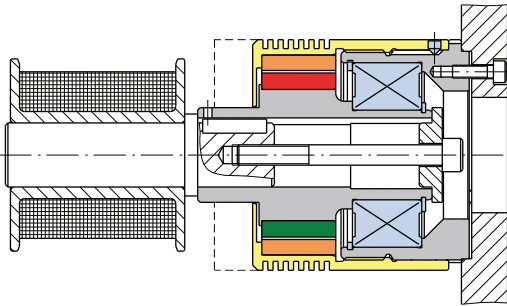

The winding drum is mounted directly onto the clutch. The clutch functions as a bearing for the winding drum and is rigidly connected to a machine wall (used as a brake for tensile force limitation of the coiled material).

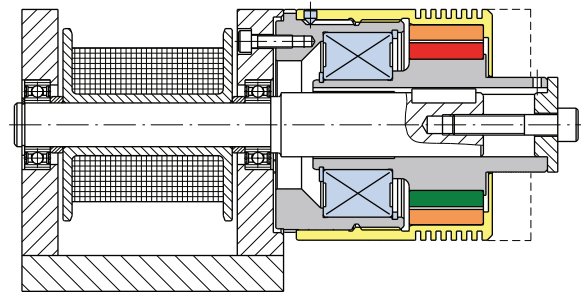

The winding drum is bearing-mounted separately. The clutch has no bearing function and is fixed rigidly to the machine wall (used as a brake for tensile force limitation of the coiled material).

ROBA®-contitorque with flexible shaft coupling (used as a brake)

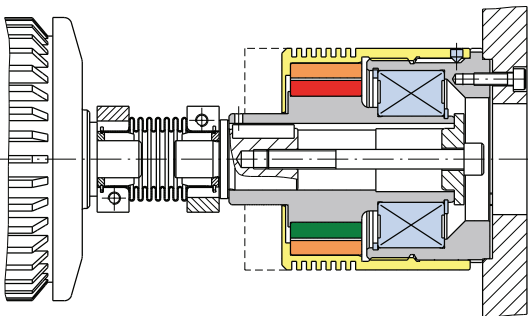

The clutch is rigidly connected to a machine wall and connected directly to the motor shaft via a flexible shaft coupling (used as a brake for the application of different loads onto the motor).

ROBA®-contitorque (special design) for the connection of two bearing-mounted shafts (used as a clutch)

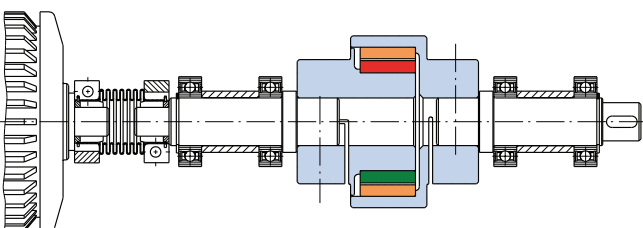

Special design for the connection of two separately bearing-mounted shafts. The clutch does not have its own bearing. The two clutch halves are secured to the two shafts using clamping hubs (used as a clutch for torque limitation).

Headquarters

Chr. Mayr GmbH + Co. KG
Eichenstrasse 1, D-87665 Mauerstetten
Tel.: 0 83 41/8 04-0, Fax: 0 83 41/80 44 21
www.mayr.com, E-Mail: info@mayr.com



mayr[®]

Service Germany

Baden-Württemberg

Esslinger Straße 7
70771 Leinfelden-Echterdingen
Tel.: 07 11/45 96 01 0
Fax: 07 11/45 96 01 10

Bavaria

Eichenstrasse 1
87665 Mauerstetten
Tel.: 0 83 41/80 41 04
Fax: 0 83 41/80 44 23

Chemnitz

Bornaer Straße 205
09114 Chemnitz
Tel.: 03 71/4 74 18 96
Fax: 03 71/4 74 18 95

Franken

Unterer Markt 9
91217 Hersbruck
Tel.: 0 91 51/81 48 64
Fax: 0 91 51/81 62 45

Hagen

Im Langenstück 6
58093 Hagen
Tel.: 0 23 31/78 03 0
Fax: 0 23 31/78 03 25

Kamen

Lünener Strasse 211
59174 Kamen
Tel.: 0 23 07/23 63 85
Fax: 0 23 07/24 26 74

North

Schiefer Brink 8
32699 Extertal
Tel.: 0 57 54/9 20 77
Fax: 0 57 54/9 20 78

Rhine-Main

Hans-Böckler-Straße 6
64823 Groß-Umstadt
Tel.: 0 60 78/7 82 53 37
Fax: 0 60 78/9 30 08 00

Branch office

China

Mayr Zhangjiagang
Power Transmission Co., Ltd.
Changxing Road No. 16,
215600 Zhangjiagang
Tel.: 05 12/58 91-75 65
Fax: 05 12/58 91-75 66
info@mayr-ptc.cn

Great Britain

Mayr Transmissions Ltd.
Valley Road, Business Park
Keighley, BD21 4LZ
West Yorkshire
Tel.: 0 15 35/66 39 00
Fax: 0 15 35/66 32 61
sales@mayr.co.uk

France

Mayr France S.A.
Z.A.L. du Minopole
BP 16
62160 Bully-Les-Mines
Tel.: 03.21.72.91.91
Fax: 03.21.29.71.77
contact@mayr.fr

Italy

Mayr Italia S.r.l.
Viale Veneto, 3
35020 Saonara (PD)
Tel.: 0 49/8 79 10 20
Fax: 0 49/8 79 10 22
info@mayr-italia.it

Singapore

Mayr Transmission (S) PTE Ltd.
No. 8 Boon Lay Way Unit 03-06,
TradeHub 21
Singapore 609964
Tel.: 00 65/65 60 12 30
Fax: 00 65/65 60 10 00
info@mayr.com.sg

Switzerland

Mayr Kupplungen AG
Tobelackerstrasse 11
8212 Neuhausen am Rheinfall
Tel.: 0 52/6 74 08 70
Fax: 0 52/6 74 08 75
info@mayr.ch

USA

Mayr Corporation
4 North Street
Waldwick
NJ 07463
Tel.: 2 01/4 45-72 10
Fax: 2 01/4 45-80 19
info@mayrcorp.com

Representatives

Australia

Transmission Australia Pty. Ltd.
22 Corporate Ave,
3178 Rowville, Victoria
Australien
Tel.: 0 39/7 55 44 44
Fax: 0 39/7 55 44 11
info@transaus.com.au

China

Mayr Power Transmission Co., Ltd.
Shanghai Representative Office
Room 2206, No. 888 Yishan Road
200233 Shanghai, VR China
Tel.: 0 21/64 32 01 60
Fax: 0 21/64 57 56 21
Trump.feng@mayr.de

India

National Engineering
Company (NENCO)
J-225, M.I.D.C.
Bhosari Pune 411026
Tel.: 0 20/27 13 00 29
Fax: 0 20/27 13 02 29
nenco@nenco.org

Japan

MATSUI Corporation
2-4-7 Azabudai
Minato-ku
Tokyo 106-8641
Tel.: 03/35 86-41 41
Fax: 03/32 24 24 10
k.goto@matsui-corp.co.jp

South Africa

Torque Transfer
Private Bag 9
Elandsfontein 1406
Tel.: 0 11/8 99 00 00
Fax: 0 11/8 99 65 74
torque@bearings.co.za

South Korea

Mayr Korea Co. Ltd.
Room No.1002, 10th floor,
Nex Zone, SK TECHNOPARK,
77-1, SungSan-Dong,
SungSan-Gu, Changwon, Korea
Tel.: 0 55/2 62-40 24
Fax: 0 55/2 62-40 25
info@mayrkorea.com

Taiwan

German Tech Auto Co., Ltd.
No. 28, Fenggong Zhong Road,
Shengang Dist.,
Taichung City 429, Taiwan R.O.C.
Tel.: 04/25 15 05 66
Fax: 04/25 15 24 13
abby@zfgta.com.tw

Machine tools

Applications in China
Dynamic Power Transmission Co., Ltd.
Block 5th, No. 1699, Songze Road,
Xujing Industrial Zone
201702 Shanghai, China
Tel.: 021/59883978
Fax: 021/59883979
dpcshanghai@online.sh.cn

More representatives:

Austria, Benelux States, Brazil, Canada, Czech Republic, Denmark, Finland, Greece, Hongkong, Hungary, Indonesia, Israel, Malaysia, New Zealand, Norway, Philippines, Poland, Romania, Russia, Slovakia, Slovenia, Spain, Sweden, Thailand, Turkey

You can find the complete address for the representative responsible for your area under www.mayr.com in the internet.

mayr[®]
your reliable partner